

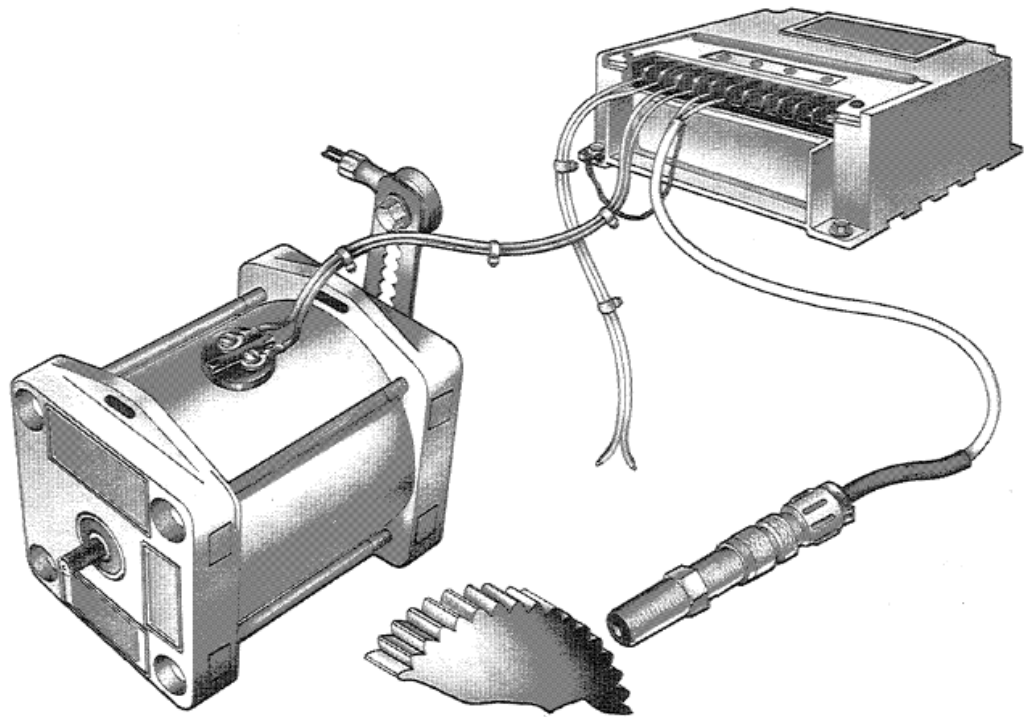

Reference Manual



Electronic Control Installation Guide

Manual 25070D



WARNING

Read this entire manual and all other publications pertaining to the work to be performed before installing, operating, or servicing this equipment. Practice all plant and safety instructions and precautions. Failure to follow instructions can cause personal injury and/or property damage.

The engine, turbine, or other type of prime mover should be equipped with an overspeed shutdown device to protect against runaway or damage to the prime mover with possible personal injury, loss of life, or property damage.

The overspeed shutdown device must be totally independent of the prime mover control system. An overtemperature or overpressure shutdown device may also be needed for safety, as appropriate.



CAUTION

To prevent damage to a control system that uses an alternator or battery-charging device, make sure the charging device is turned off before disconnecting the battery from the system.

Electronic controls contain static-sensitive parts. Observe the following precautions to prevent damage to these parts.

- Discharge body static before handling the control (with power to the control turned off, contact a grounded surface and maintain contact while handling the control).
- Avoid all plastic, vinyl, and Styrofoam (except antistatic versions) around printed circuit boards.
- Do not touch the components or conductors on a printed circuit board with your hands or with conductive devices.



IMPORTANT DEFINITIONS

WARNING—indicates a potentially hazardous situation which, if not avoided, could result in death or serious injury.



CAUTION—indicates a potentially hazardous situation which, if not avoided, could result in damage to equipment.



NOTE—provides other helpful information that does not fall under the warning or caution categories.

Contents

ELECTRONIC CONTROL INSTALLATION GUIDE	2
General	2
Handling	2
Linkage	3
Control Installation	4
Wiring.....	4
Switching	6
Power Input and Power Supplies	6
Start-up.....	7
Wiring for Load Sharing Controls	7

Illustrations and Tables

Figure 1. Linear Linkage.....	3
Figure 2. Carburetor Compensating Linkage	3
Figure 3. Correct and Incorrect Wiring to Battery.....	5
Figure 4. High Voltage Selector, External Diode.....	8
Figure 5. High Voltage Selector, Internal Diode.....	8
Figure 6. High Voltage Selector, External and Internal Diode	8
Figure 7. Hardwired Paralleling Line Common	8
Table 1. Controls with Internal Diodes	8

Electronic Control Installation Guide

General

This guide provides general information covering installation and wiring of Woodward electronic controls. It cannot cover all application sites. Because each site has its own conditions, it may be necessary to solve problems in ways not mentioned in this manual. It is sometimes necessary to eliminate problems by trial-and-error techniques. Contact Woodward for assistance.

Electronic controls can be affected by conducted and radiated electrical interference just as hydromechanical controls can be affected by shock, vibration, and changing oil supply pressure. Low voltage, low current, and high impedance signals are more sensitive to electrical interference than high voltage, high current, and low impedance signals.

The effect of electrical interference is either erratic and unpredictable performance or failure to perform. Following this guide will minimize those effects. Incorrect installation often causes poor performance and serious start-up problems.

These recommendations apply to all electronic controls and auxiliaries designed and built by Woodward Industrial Controls.

Refer to the electronic control's manual and plant wiring drawing for information about your specific control. These supercede any information in this guide.



WARNING

The engine, turbine, or other type of prime mover should be equipped with an overspeed shutdown device to protect against runaway or damage to the prime mover with possible personal injury, loss of life, or property damage.

The overspeed shutdown device must be totally independent of the prime mover control system. An overtemperature or overpressure shutdown device may also be needed for safety, as appropriate.

Handling

1. The high input impedance of some semiconductors makes them susceptible to damage from static discharges. For this reason, avoid touching printed circuit board terminals and external terminal blocks. If printed circuit boards must be removed from a control, put a conductive plastic strips over exposed connector pins and place the printed circuit board in a conductive plastic bag (see manual 82715, *Guide for Handling and Protection: Electronic Controls, Printed Circuit Boards, Modules*).
2. Calibration and test instruments should be battery powered. Line powered instruments, due to earth grounding, can give inaccurate results and may damage controls when their connection to the governor forms a ground loop. Isolating the instrument from power line ground usually violates electrical wiring codes. Double check all connections before attaching jumpers, probes, etc.

Linkage

1. If the actuator is part of an Electrically Powered Governor (EPG), choose a mounting location that allows installation of a suitable linkage, provides protection from sources of heat, and meets the wire length limitations stated in the appropriate manual.
2. Check the linkage between the actuator and the engine's fuel control. It must move freely, without friction and without backlash. Use good quality rod end connectors.



NOTE

To ensure proper operation, the linkage must be checked periodically. To check the linkage, mark the actuator shaft and lever to align the lever when finished checking. Remove the lever from the shaft. Manually stroke the linkage as if the actuator were moving it. The linkage must move freely with no binding and no rough spots. Lubricate or replace parts as required. Reattach the lever to the shaft, noting the alignment marks.

3. A linear linkage arrangement (see Figure 1) should be used unless the fuel control is non-linear. Most fuel controls except carburetors are linear.
4. Carbureted engines should have a carburetor compensating linkage (see Figure 2).
5. The link which connects the actuator lever to the fuel control lever should not be so long that it flexes.
6. Note the direction of travel for increased fuel. Most actuators are available with clockwise or counterclockwise rotation for increased fuel.
7. Be sure the actuator is capable of moving the fuel control to its minimum and maximum fuel limits. Set the linkage so that the actuator is just above minimum when the fuel control is at its minimum stop and (except for Detroit Diesel engines) so that the actuator is just below maximum when the fuel control is at its maximum stop.



NOTE

EGB2P actuators have excess travel in the decrease-fuel direction when the prime mover is not running. Set the linkage so that the prime mover's fuel control is at its minimum fuel position when the EGB2P pointer is just above the minimum fuel mark on the dial.

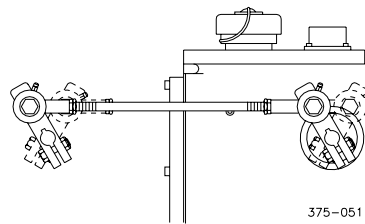

Figure 1. Linear Linkage

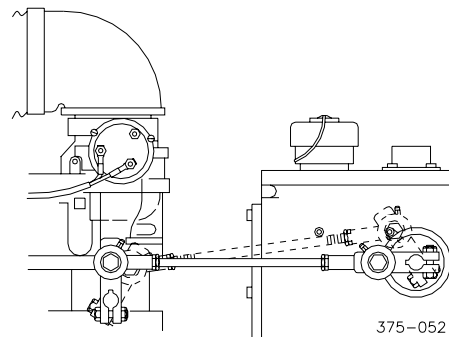



Figure 2. Carburetor Compensating Linkage (minimum fuel shown with solid lines; maximum fuel shown with dashed lines)

Control Installation

1. Controls in die cast enclosures are designed to permit engine skid mounting. All others should be protected from direct water contact and not mounted on the engine skid.
2. Adequate ventilation should be available for cooling. Shield controls and wiring from heat sources such as exhaust manifolds and turbochargers.
3. Controls should not be installed near high voltage or high current devices such as switch gear and starter solenoids.
4. Allow enough space for servicing the control.
5. Ambient temperature should be within limits. See the appropriate manual.
6. Tie the control chassis to system ground for proper shield termination and circuit board shielding.
7. Note wire length limitations when mounting.

Wiring

1. Even if currents are low, wire should be 0.3 mm² (22 AWG) or larger for mechanical strength. In most cases wire need not be larger than 0.8 mm² (18 AWG).
2. All connections should be mechanically and electrically secure. Connections made by soldering, crimping, etc., should only be done with the correct tools and procedures.
3. Do not allow sharp bends in the wiring. Keep bends away from objects which could wear through insulation.
4. Do not subject wires, connectors, switches, etc., to temperatures beyond their design limits.
5. Use insulated terminals to connect wires to the control terminal blocks.
6. If the symbol  is shown, twisted, shielded wire should be used. The number of lines through the symbol is the number of wires within the shield. A braided shield is best for protection against power frequencies (50 and 60 Hz). Radio frequency interference is best minimized by a foil shield.

Connect shields as shown on the plant wiring diagram (some controls require shields to be passed through the control connector and terminated internally). Terminate shields for most controls at a chassis screw. Die cast enclosures have a screw on the front edge for this purpose. For sheet metal controls, use a screw at the side of the terminal block. Only one end (the end nearest the electrical control) of each shield should be tied to ground. All shields are usually tied to the same point.

When passing shields through connectors and terminal blocks, treat each shield as if it were a signal wire. Each shield must be given its own pin or terminal and be kept insulated from nearby wires and metal conductors. Do not tin (solder) braided shields.

Connect the control chassis to system ground (.

7. The best shielding is obtained by installing wires in steel conduit. Good shielding is obtained if control wires are installed in a separate cable duct. This conduit or duct should not contain any high voltage or high current cables. If control wires have to cross high voltage or high current conductors, make them cross at a 90 degree angle.
8. This item applies to Woodward controls connected to a dc power source, such as a battery. Connect the power leads directly to the battery terminals. This is mandatory for Electrically Powered Governors (EPGs) and sometimes mandatory, and always helpful, for other electronic controls. Do not connect these leads to power distribution points. Do not use these leads to provide power to other devices. See Figure 3.

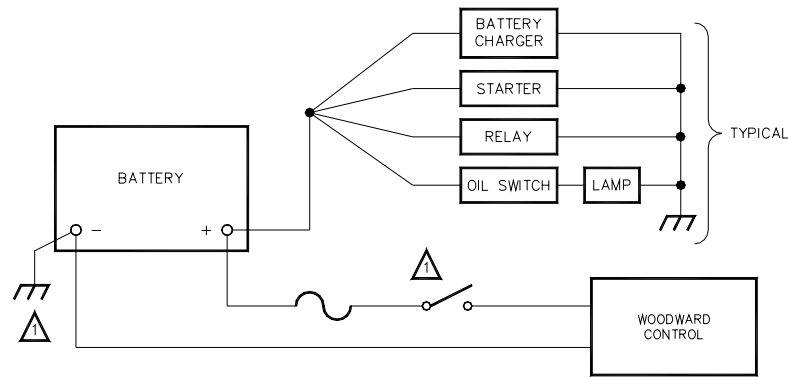

RIGHT

NOTE:

⚠ A NEGATIVE GROUND SYSTEM IS SHOWN. IF A POSITIVE GROUND SYSTEM IS USED, THE SWITCH AND FUSE MUST BE LOCATED IN SERIES WITH BATTERY (-) AND TERMINAL (TB1-2) ON THE WOODWARD CONTROL. THE POSITIVE TERMINAL BECOMES CHASSIS GROUND.

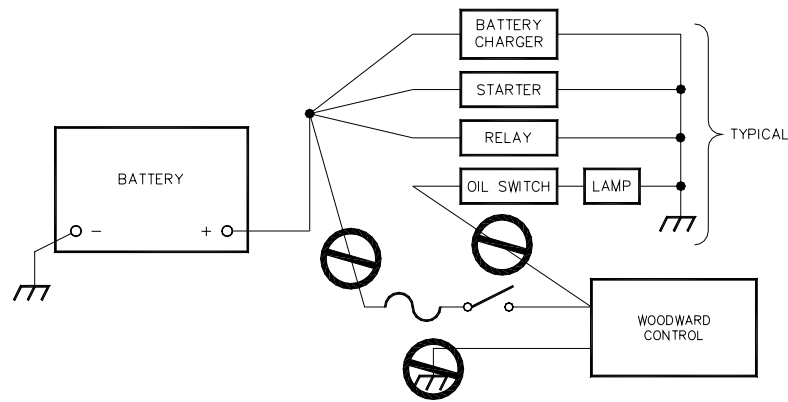

WRONG

824-143
97-08-22 skw

Figure 3. Correct and Incorrect Wiring to Battery

9. Electrically Powered Governors, by definition, obtain control and actuator power from electrical sources. This requires that wires to the power source (battery) be as short as possible and 4 mm² (12 AWG) or larger. Refer to the appropriate product specification or manual for wire length limits. Because these controls can generate interference and are sensitive to interference from other sources, use stranded wire and connect the power leads directly to the source or battery. See item 8 above. These leads may be twisted to minimize interference. The lead to the non-grounded battery terminal should have a circuit breaker or slow blow fuse and switch.
10. Thermocouple wires should go through as few connections as possible and must use the same type wire from the junction, through all connections, to the control input terminals. For example, if a chromel-alumel junction is used, the wire from the junction to the control must also be Cr-Al. Observe correct polarity.
11. Controls that are mounted on slides are pulled out of the rack for calibration and repair. Use a service loop in the pigtail to allow the control to extend.
12. Refer to "Wiring for Load Sharing Controls" below for more wiring information for load sharing systems.

Switching

1. If low level signals such as:
 - Paralleling lines
 - Droop-isochronous control
 - Speed trim
 - Thermocouple
 - Process control signalsare being switched, use high quality switches and hermetically sealed relays designed for low current signals. Mercury wetted relays are suitable.
2. Speed trim potentiometers, located in a different room from the control, usually require special shielding. In such cases, it is better to use a motor operated potentiometer located at the control. The distance from the MOP raise-lower switch to the MOP is not critical.

Power Input and Power Supplies

1. Refer to "Handling" for wiring information. For load sharing applications also refer to "Wiring for Load Sharing Controls".
2. Sources powering Woodward controls and power supplies frequently generate more conducted interference (voltage spikes and excessive ripple) than other items connected to Woodward controls. Two remedies are possible: Interference can be minimized at the source, or the controls can be made more resistant to interference. All Woodward controls of recent design have spike protection and regulated internal power supplies. Additional protection may be required in extreme cases. This is best determined by using an oscilloscope.
3. It will help if the devices which generate voltage spikes have spike suppressors attached. These can be varistors, TransZorbs, capacitors, or line filters. Every dc relay coil and solenoid should have a diode. Severe voltage spikes can damage Woodward controls and power supplies.

4. Extremely noisy environments may require a separate, isolated power supply for each control. This can be either a separate battery and charger or a dc-to-dc or ac-to-dc supply. The separate supply is better than another battery and charger due to charger ripple. Also, the separate supply can be located close to the control. Woodward has power supplies appropriate for Woodward controls that accommodate various input voltages. Contact Woodward for power supply information.
5. The supply voltage must not exceed the allowable range. For example, a 36 volt cranking battery which is charged at 42 volts will damage a load sharing and speed control with a 20 to 40 volt input range.

Start-up

Read the overspeed warning at the beginning of this manual. Follow the pre-start checks and adjustments in the appropriate control manual.



WARNING

Be prepared to make an emergency shutdown when starting the engine, turbine, or other type of prime mover, to protect against runaway or overspeed with possible personal injury, loss of life, or property damage.

Wiring for Load Sharing Controls

In order to provide state-of-the-art products of high reliability and performance, Woodward improves the design of its controls, such as the 2301 Load Sharing and Speed Controls (LSSCs), as technology improves. While compatibility with earlier controls is a design goal, sometimes differences do exist. This section shows how to achieve best load sharing when similar or different 2301 Load Sharing and Speed Controls are used.

Recommendations

1. Follow the plant wiring diagram for the specific control, and refer to the "Wiring" section of this manual.
2. Both of the control's paralleling lines should be disconnected from the paralleling line bus when the generator set is dropped from the line. See item 1 of "Switching".
3. High supply voltage selector: When operating a number of controls in load sharing applications which have separate power sources and a common return, use a high supply voltage selector. See Figures 4, 5, and 6. This ensures optimum load sharing accuracy and minimizes system sensitivity to noise on the power supplies. The current rating for each diode should be 1 amp times the number of gray LSSCs plus 0.4 amp times the number of beige LSSCs in the system. This scheme will automatically select the battery with the highest voltage and use it to power all units. To remove power from any control, interrupt the power to both positive and negative power supply wires.

When using the following controls, the external diode is not necessary because it is already in the controls.

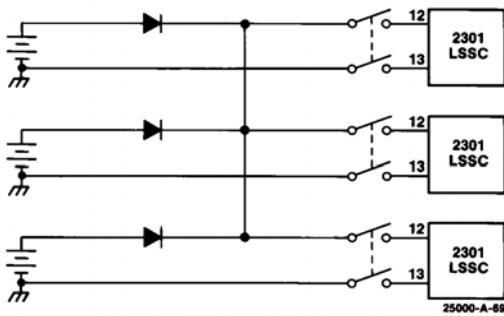

Figure 4. High Voltage Selector, External Diode

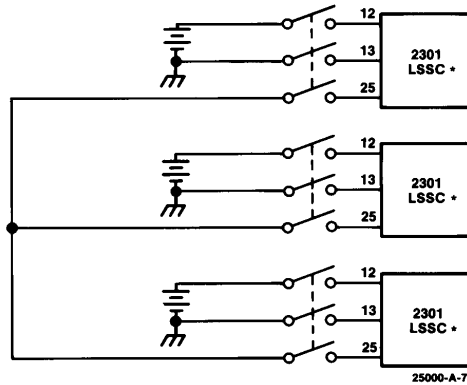

Figure 5. High Voltage Selector, Internal Diode

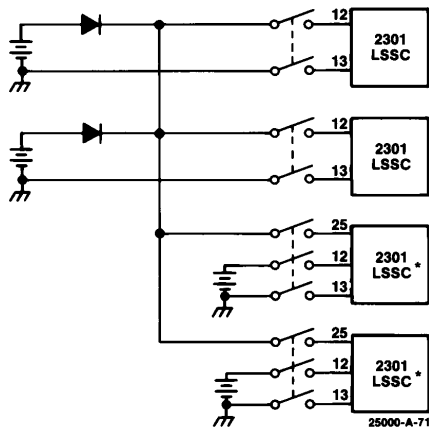

Figure 6. High Voltage Selector, External and Internal Diode

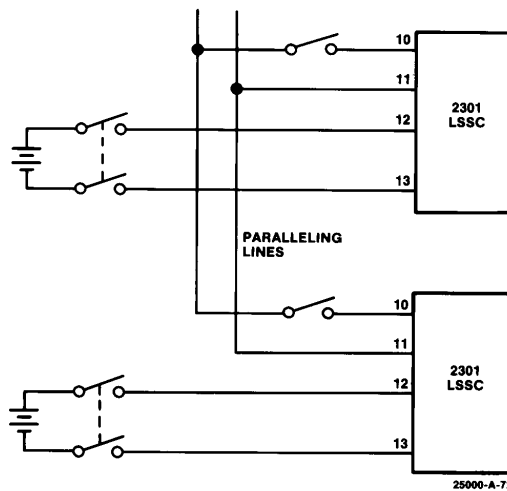

Figure 7. Hardwired Paralleling Line Common

Table 1. Controls with Internal Diodes

8271-422	8271-472	8271-652	8271-706
8271-444	8271-473	8271-676	8271-747
8271-467	8271-542	8271-679*	8290-009

*—8271-679 is used only on gas turbines and has different terminal numbers. Refer to the plant wiring drawing.

These newer controls are also identified by no label at terminal 25, and "20–40 Vdc" at terminals 12 and 13. Older controls (which require external diodes) have "32 Vdc" at terminal 25 and "24 Vdc" at terminals 12 and 13. With the newer controls, the high voltage selector scheme is accomplished by connecting terminals 25 on the individual controls. See Figure 5.

When using this scheme, it is necessary to switch terminal 25 as well as the positive and negative power input.

Alternatives

In many cases it is easier to obtain the desired performance by varying from the five recommended items previously listed:

1. One supply can be used to power all load sharing controls. This eliminates the need for recommendation 5. All other recommendations apply.
2. An isolated power supply can be used for each load sharing control. See item 4 of "Power Input and Power Supplies". In this case terminal 11 need not be disconnected from the paralleling line bus when the generator is not paralleled. See Figure 7.
3. If, when using the high supply voltage selector scheme for controls listed in Table 1, power is disconnected by interrupting the positive and negative inputs and terminal 25, it is not necessary to disconnect terminal 11 from the paralleling line bus when the generator is not paralleled.

Consequences

Failure to follow the recommendations of this section can cause the following problems:

1. Uneven load distribution. This refers to steady-state conditions, not to transient conditions. Load sharing that is not proportional may be caused by using controls of different generations if excessive resistance (4Ω or more) is present between terminals 11 of contact resistance in the switching relay for the paralleling lines or very long paralleling line runs. To assure low contact resistance, use a high-quality, low-level signal relay, preferably one that is hermetically sealed. See item 1 of "Switching". If paralleling line length is between 45 and 490 meters (150 and 1600 feet) use 2 mm^2 (14 AWG) shielded wire. Refer to the load sharing control manual for other causes of uneven load distribution.
2. Instability when paralleled. This can be caused by not using a high supply selector as described in recommendation 5. Refer to the appropriate load sharing control manual for other causes of instability.

If problems are encountered with the installation or operation of this governor, contact Woodward (see Location information on our website, www.woodward.com).

We appreciate your comments about the content of our publications.

Send comments to: icinfo@woodward.com

Please include the manual number from the front cover of this publication.



PO Box 1519, Fort Collins CO 80522-1519, USA
1000 East Drake Road, Fort Collins CO 80525, USA
Phone +1 (970) 482-5811 • Fax +1 (970) 498-3058

Email and Website—www.woodward.com

**Woodward has company-owned plants, subsidiaries, and branches,
as well as authorized distributors and other authorized service and sales facilities throughout the world.**

Complete address / phone / fax / email information for all locations is available on our website.